

THE INFORMATION CONTAINED IN THIS DRAWING IS THE SOLE PROPERTY OF ANDERSON POWER PRODUCTS. ANY REPRODUCTION IN PART OR WHOLE WITHOUT THE WRITTEN PERMISSION OF ANDERSON POWER PRODUCTS IS PROHIBITED.

Copyright 2005

ANDERSON POWER PRODUCTS RESERVES THE RIGHT TO ALTER PRODUCT TYPES, THEIR TECHNICAL DATA, DIMENSION, STYLE AND ACCESSORIES WITHOUT PRIOR NOTIFICATION.

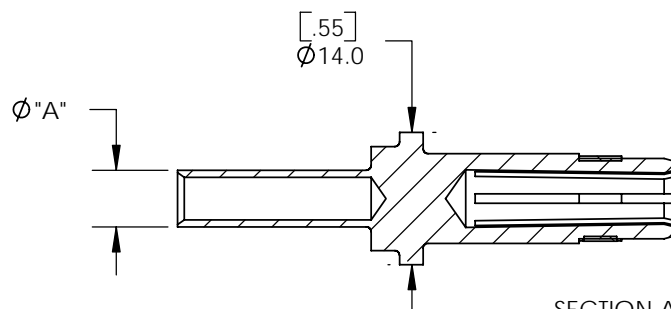
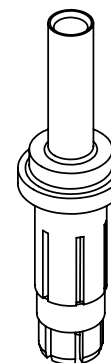
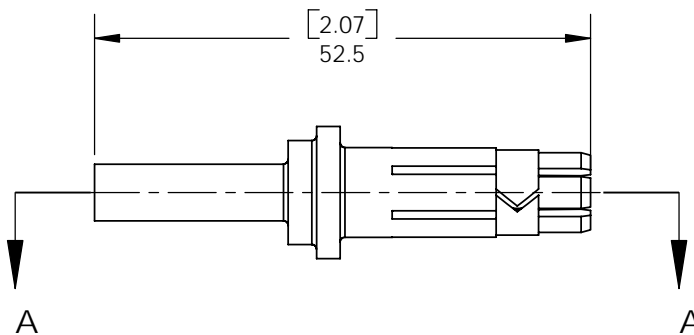
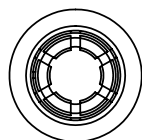

SECTION A-A

CAT. NO.	DESCRIPTION	"A"
80-1110	80A SOCKET (10MM WIRE)	6.0[.24]
80-1116	80A SOCKET (16MM WIRE)	8.4[.33]
80-1125	80A SOCKET (25MM WIRE)	11.0[.43]
80-1135	80A SOCKET (35MM WIRE)	12.5[.49]

DIMENSIONS ARE IN:	<input checked="" type="checkbox"/> INCH[MM]	MM[INCH]
UNLESS OTHERWISE STATED		
TOLERANCES:		
DECIMALS (INCH)	DECIMALS (MM)	ANGLES
XX ± .02	X ± .5	± 2°
SURFACE FINISH:		
MACHINED	128 [3.2] ✓	
MOLDED	64 [1.6] ✓	
MATERIAL: COPPER ALLOY		
FINISH: SILVER PLATE		

APPROVALS	
DRAWN	AMP 5/13/05
CHECKED	DJD 5/17/05
MFG APP	CHB 5/13/05
QC APP	UFN 5/13/05
ENG APP	DAM 5/13/05

 ANDERSON POWER PRODUCTS		
TITLE		
EBC DIN CONTACT 80A SOCKET SALES OUTLINE		
SIZE	DWG NO.	REV.
A/A4	80-1100S1	0
SCALE	CADFILE	SHEET
NONE	02306	1 OF 1

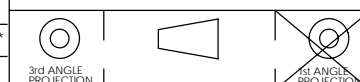

-CAD GENERATED DRAWING-
DO NOT MANUALLY UPDATE
DO NOT SCALE

REV.	DESCRIPTION OF CHANGES	APPROVED	DATE
*	*****	***	*****