

THE INFORMATION CONTAINED IN THIS DRAWING IS THE SOLE PROPERTY OF ANDERSON POWER PRODUCTS. ANY REPRODUCTION IN PART OR WHOLE WITHOUT THE WRITTEN PERMISSION OF ANDERSON POWER PRODUCTS IS PROHIBITED.

Copyright 2006

ANDERSON POWER PRODUCTS RESERVES THE RIGHT TO ALTER PRODUCT TYPES, THEIR TECHNICAL DATA, DIMENSION, STYLE AND ACCESSORIES WITHOUT PRIOR NOTIFICATION.

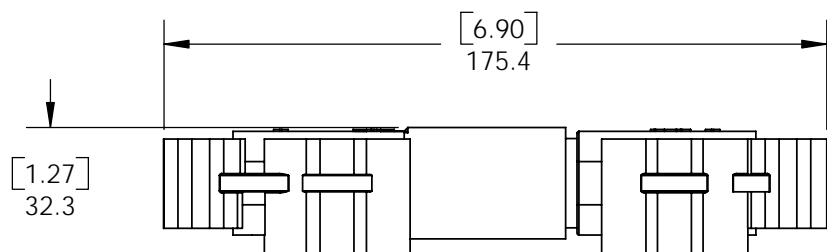
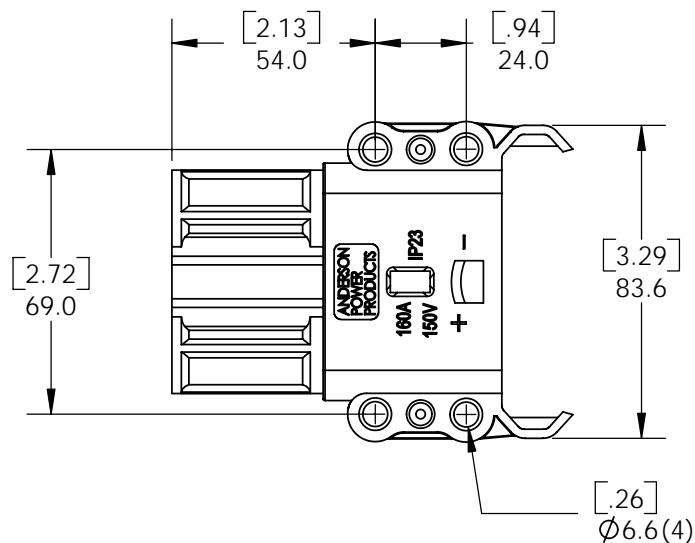
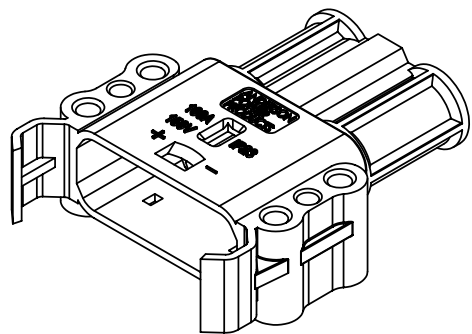

MATED PAIR

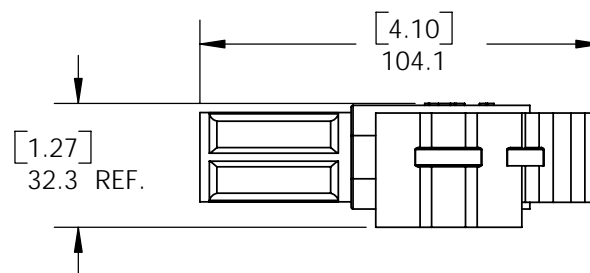

PART NO.	DESCRIPTION	MATERIAL	COLOR
160-2	ABC SOCKET HSG. (160A)	NYLON	BLACK
E160-2	EBC SOCKET HSG. (160A)	PP	GRAY
EN160-2	EBC SOCKET HSG. (160A)	NYLON	BLACK
EP160-2	EBC SOCKET HSG. (160A)	PBT-PC BLEND	GRAY

DIMENSIONS ARE IN:	INCH[MM]	MM[INCH]
UNLESS OTHERWISE STATED		
TOLERANCES:		
DECIMALS (INCH)	DECIMALS (MM)	ANGLES
XX ± .02	X ± .5	± 2°
SURFACE FINISH:		
MACHINED	128 [3.2]	✓
MOLDED	64 [1.6]	✓
MATERIAL: SEE DATA SHEET FOR MATERIAL SPECS		
FINISH: N/A		

APPROVALS	
DRAWN	AMP 6/7/05
CHECKED	DJD 6/9/05
MFG APP	CHB 6/7/05
QC APP	JJA 6/9/05
ENG APP	DAM 6/8/05

ANDERSON POWER PRODUCTS		
TITLE		
SALES OUTLINE		
160A FEMALE SOCKET HOUSING		
SIZE	DWG NO.	REV.
A/A4	E160-2S1	1
SCALE	CADFILE	SHEET
NONE	02357	1 OF 1

1	ECRN 13946 - ADD "EP" & "EN" SERIES PART NUMBERS	AMS	01/19/06
REV.	DESCRIPTION OF CHANGES	APPROVED	DATE



-CAD GENERATED DRAWING-
DO NOT MANUALLY UPDATE
DO NOT SCALE