

THE INFORMATION CONTAINED IN THIS DRAWING IS THE SOLE PROPERTY OF ANDERSON POWER PRODUCTS. ANY REPRODUCTION IN PART OR WHOLE WITHOUT THE WRITTEN PERMISSION OF ANDERSON POWER PRODUCTS IS PROHIBITED.

Copyright 2006

ANDERSON POWER PRODUCTS RESERVES THE RIGHT TO ALTER PRODUCT TYPES, THEIR TECHNICAL DATA, DIMENSION, STYLE AND ACCESSORIES WITHOUT PRIOR NOTIFICATION.

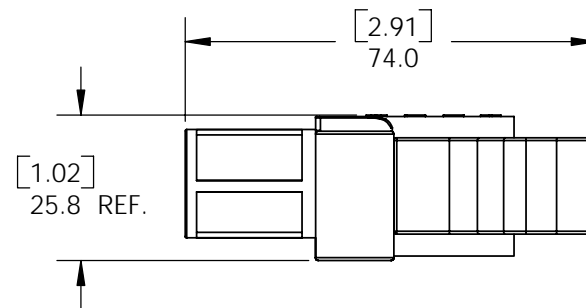
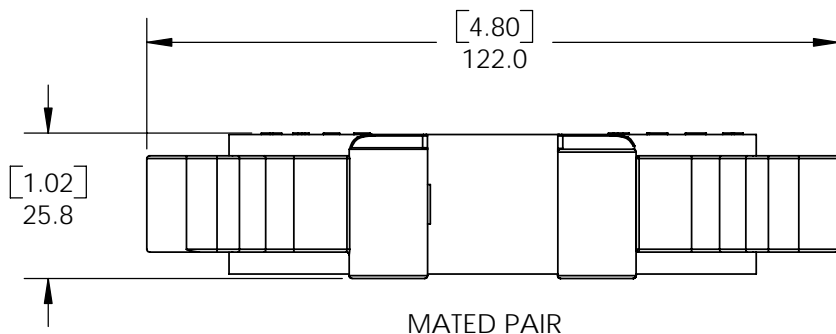
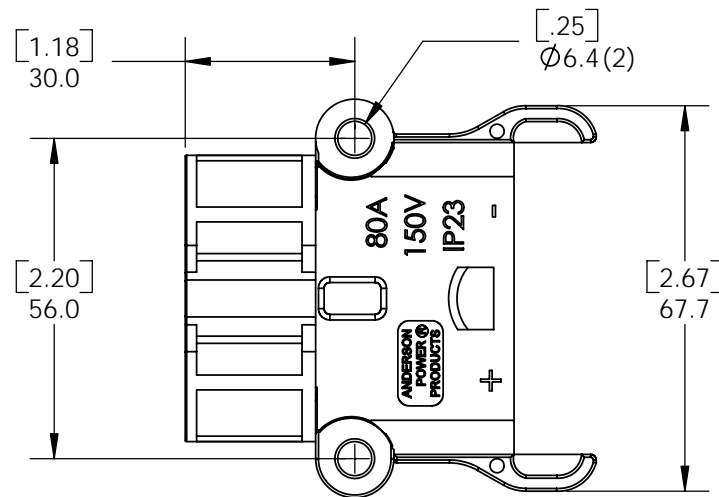
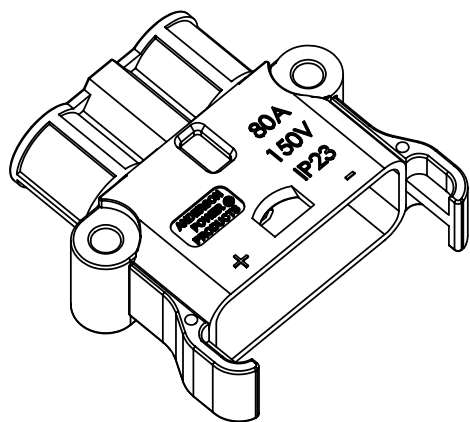

PART NO.	DESCRIPTION	MATERIAL	COLOR
80-2	ABC SOCKET HSG. (80A)	NYLON	BLACK
E80-2	EBC SOCKET HSG. (80A)	PP	GRAY
EN80-2	EBC SOCKET HSG. (80A)	NYLON	BLACK
EP80-2	EBC SOCKET HSG. (80A)	PBT-PC BLEND	GRAY

DIMENSIONS ARE IN:	INCH[MM]	MM[INCH]
UNLESS OTHERWISE STATED		
TOLERANCES:		
DECIMALS (INCH)	DECIMALS (MM)	ANGLES
XX ± .02	X ± .5	± 2°
SURFACE FINISH:		
MACHINED	128 [3.2]	✓
MOLDED	64 [1.6]	✓
MATERIAL: SEE DATA SHEET FOR MATERIAL SPECS		
FINISH: N/A		

APPROVALS	
DRAWN	AMP 6/7/05
CHECKED	DJD 6/9/05
MFG APP	CHB 6/7/05
QC APP	JJA 6/9/05
ENG APP	DAM 6/8/05

ANDERSON POWER PRODUCTS

TITLE: SALES OUTLINE
80A FEMALE SOCKET HOUSING

SIZE: A/A4 DWG NO.: E80-2S1 REV.: 1

SCALE: NONE CADFILE: 02360 SHEET: 1 OF 1



1	ECRN 13946 - ADD "EP" & "EN" SERIES PART NUMBERS	AMS	01/19/06
REV.	DESCRIPTION OF CHANGES	APPROVED	DATE

-CAD GENERATED DRAWING-
DO NOT MANUALLY UPDATE
DO NOT SCALE